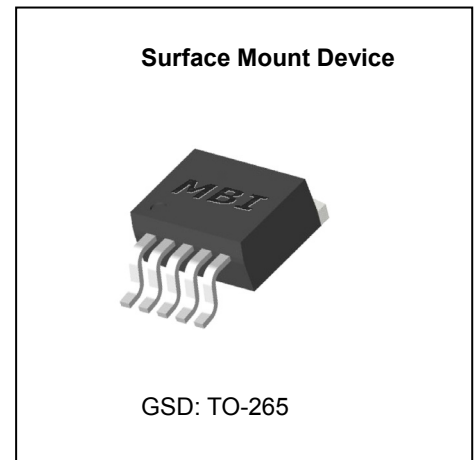

**All-Ways-On™ High-Power LED Driver****Features**

- Constant output current invariant to supply and load voltage change
- Maximum output constant current: 1.2A
- Output current adjusted through an external resistor
- Built-in thermal protection
- 5V supply voltage
- Package type: "Pb-free" package

**Product Description**

MBI1801 is an instant On/Off LED driver for high power LED applications and exploits PrecisionDrive™ and All-Ways-On™ technology to enhance its output characteristics. At MBI1801 output stage, one regulated current port is designed to provide a uniform and constant current sink for driving LEDs within a large range of V_F variations.

With All-Ways-On™, MBI1801 easily provides users a consistent current source. Users may adjust the output current from 50 mA up to 1.2A through an external resistor, R_{ext} , which gives users flexibility in controlling the light intensity of LEDs. In addition, users can precisely adjust LED brightness from 0% to 100% via output enable (\overline{OE}) with Pulse Width Modulation. MBI1801 also guarantees that LEDs can be cascaded to maximum 17V at the output port.

Additionally, to ensure the system reliability, MBI1801 is built with Thermal Protection (TP) function. The TP function protects IC from over temperature (165°C). Also, the TO package enhances the power dissipation. As a result, a large amount of current can be sunk safely in one package.

Applications

- High-flux LED lighting

Function Block Diagram

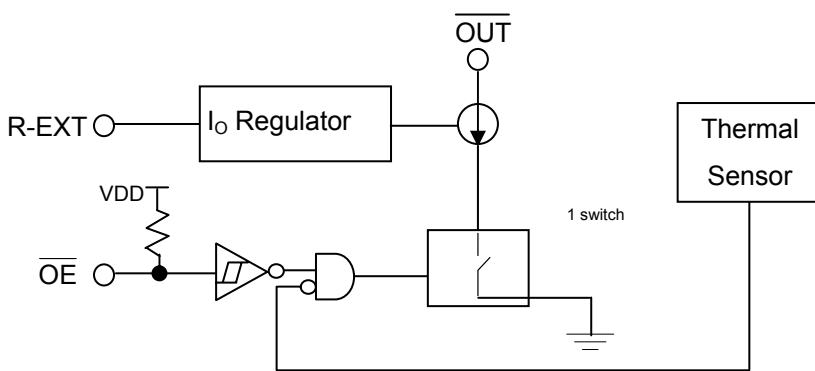
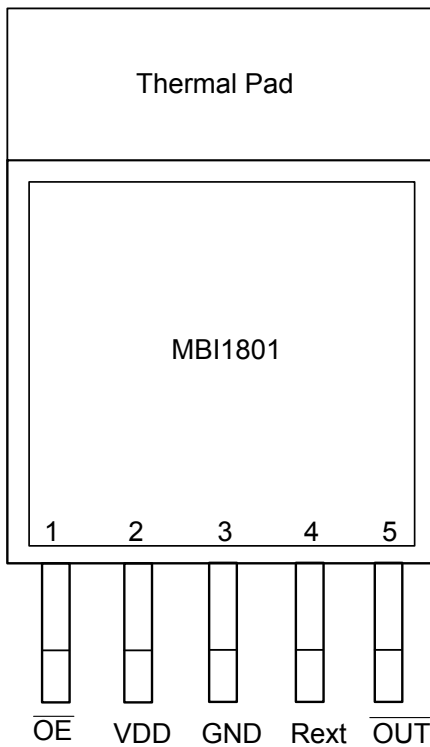

Figure 1

Pin Configuration



MBI1801GSD

Pin Description

Pin No.	Pin Name	Function
1	\overline{OE}	Output enable terminal When \overline{OE} is active (low), the output is enabled; when \overline{OE} is inactive (high), the output is turned OFF (blanked).
2	VDD	5V supply voltage terminal
3	GND	Ground terminal for control logic and current sink
4	R-EXT	Terminal used to connect an external resistor (R_{ext}) for setting up output current for the output channel
5	\overline{OUT}	Constant current output terminal
-	Thermal Pad	Power dissipation terminal connected to GND*

*To eliminate the noise influence, the thermal pad is suggested to be connected to GND on PCB.

In addition, desired thermal conductivity will be improved, if a heat-conducting device is screwed with thermal pad.

Maximum Ratings

Characteristics		Symbol	Rating	Unit
Supply Voltage		V_{DD}	0~7.0	V
Input Voltage		V_{IN}	-0.4~ $V_{DD} + 0.4$	V
Output Current		I_{OUT}	1440	mA
Sustaining Voltage		V_{DS}	-0.5~+17.0	V
GND Terminal Current		I_{GND}	1440	mA
Power Dissipation ($T_a=25^{\circ}C$)	GSD Type	P_D	1.6	W
Thermal Resistance* (On PCB, by simulation)		$R_{th(j-a)}$	21.99	$^{\circ}C/W$
Empirical Thermal Resistance* ($T_a=25^{\circ}C$)			60	$^{\circ}C/W$
Operating Temperature		T_{opr}	-40~+85	$^{\circ}C$
Operating Junction Temperature		$T_{j,max}$	125	$^{\circ}C$
Storage Temperature		T_{stg}	-55~+150	$^{\circ}C$

* Provided by factory.

Electrical Characteristics

Characteristics		Symbol	Condition	Min.	Typ.	Max.	Unit
Supply Voltage		V_{DD}	-	4.5	5.0	5.5	V
Sustaining Voltage at \overline{OUT} pin		V_{DS}	\overline{OUT} when $\overline{OE} = 5V = V_{DD}$	-	-	17.0	V
Output Current		I_{OUT}	DC Test Circuit	50	-	1200*	mA
Input Voltage	“H” level	$V_{IH,OE}$	$T_a = -40\sim 85^\circ C$	$0.7V_{DD}$	-	V_{DD}	V
	“L” level	$V_{IL,OE}$	$T_a = -40\sim 85^\circ C$	GND	-	$0.3V_{DD}$	V
Output Leakage Current		I_{OH}	$V_{OH} = 17.0V$	-	-	2.0	μA
Output Current 1		I_{OUT}	$V_{DS} = 0.6V$ $R_{ext} = 2.4k\Omega$	-	488	-	mA
Chip Skew 1		dI_{OUT}/I_{OUT}	$I_{OUT} = 488mA$ $V_{DS} = 0.6V$ $R_{ext} = 2.4k\Omega$	-	-	± 6	%
Output Current 2		I_{OUT}	$V_{DS} = 0.8V$ $R_{ext} = 1.2k\Omega$	-	976	-	mA
Chip Skew 2		dI_{OUT}/I_{OUT}	$I_{OUT} = 976mA$ $V_{DS} = 0.8V$ $R_{ext} = 1.2k\Omega$	-	-	± 12	%
Regulation of Output Current vs. Sustaining Voltage		$\%/dV_{DS}$	V_{DS} within 1.0V and 3.0V	-	± 0.1	-	% / V
Regulation of Output Current vs. Supply Voltage		$\%/dV_{DD}$	V_{DD} within 4.5V and 5.5V	-	± 1	-	% / V
\overline{OE} Pull-up Resistor		$R_{IN(up)}$	\overline{OE}	200	500	800	k Ω
Supply Current	“OFF”	$I_{DD(off) 1}$	$R_{ext} = \text{Open}, \overline{OUT} = \text{Off}$	-	5	8	mA
		$I_{DD(off) 2}$	$R_{ext} = 2.4k\Omega, \overline{OUT} = \text{Off}$	-	6	8	
		$I_{DD(off) 3}$	$R_{ext} = 1.2k\Omega, \overline{OUT} = \text{Off}$	-	8	11	
	“ON”	$I_{DD(on) 1}$	$R_{ext} = 2.4k\Omega, \overline{OUT} = \text{On}$	-	6	8	
		$I_{DD(on) 2}$	$R_{ext} = 1.2k\Omega, \overline{OUT} = \text{On}$	-	7	10	
Junction Temperature Threshold		T_x	When T_j approaches T_x and \overline{OUT} is shut off.	-	165	-	$^\circ C$

* The output current, I_{OUT} , can be driven up to 1440mA, if a heat-conducting device is applied.

Test Circuit for Electrical Characteristics

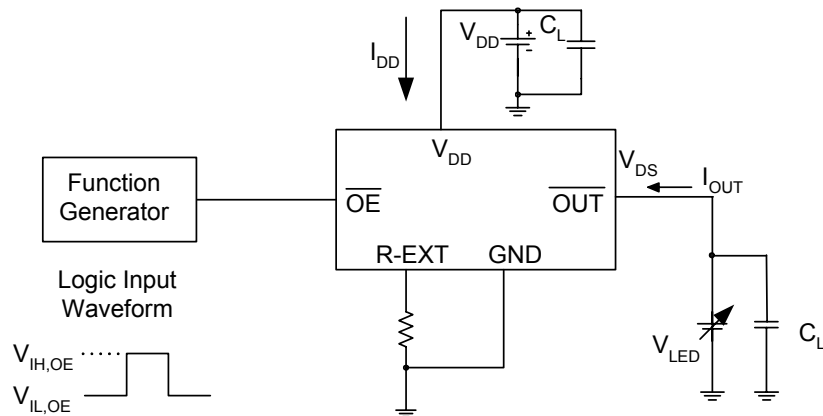

Figure 2

Switching Characteristics

Characteristic	Symbol	Condition	Min.	Typ.	Max.	Unit	
Propagation Delay Time ("L" to "H")	$\overline{OE} - \overline{OUT}$	t_{pLH}	$V_{DD} = 5.0\text{ V}$ $V_{DS} = 1\text{ V}$ $V_{IH,OE} = V_{DD}$ $V_{IL,OE} = \text{GND}$ $R_{ext} = 1200\Omega$ $(I_{OUT} = 976\text{mA})$	0.3	0.5	1	μs
Propagation Delay Time ("H" to "L")	$\overline{OE} - \overline{OUT}$	t_{pHL}		0.3	0.5	1	μs
Pulse Width	\overline{OE}	$t_{w(OE)}$		1			μs
Output Rise Time of \overline{OUT} (turn off)		t_{or}		0.3	0.5	1	μs
Output Fall Time of \overline{OUT} (turn on)		t_{of}		0.3	0.5	1	μs

Test Circuit for Switching Characteristics

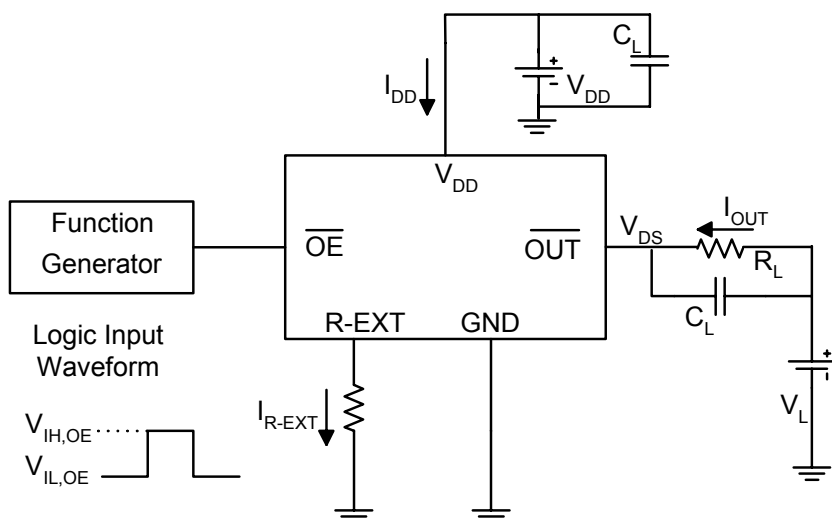

Figure 3

Application Information

Typical Application Circuits

MBI1801 application circuit

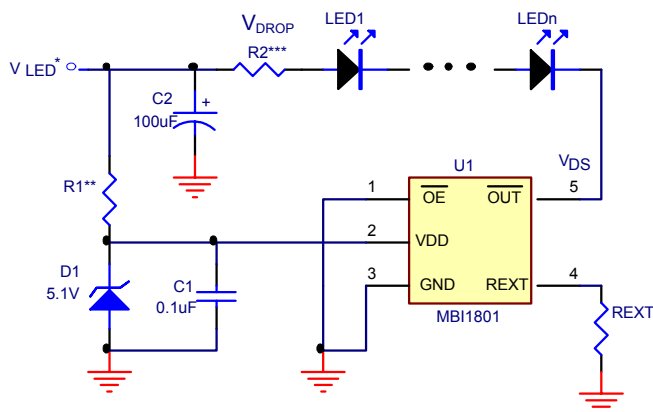

Figure 4

* $V_{LED} > V_{DS} + V_{F,LED} \times n$; $V_{F,LED}$: Forward voltage of LED; n: LED count

** $R1 = (V_{LED} - 5.1V) / I_{DD}$; refer to Electrical Characteristics for I_{DD}

*** $R2 = [V_{LED} - V_{DS} - (V_{F,LED} \times n)] / I_{LED}$

MBI1801 application circuit with brightness control by PWM signal

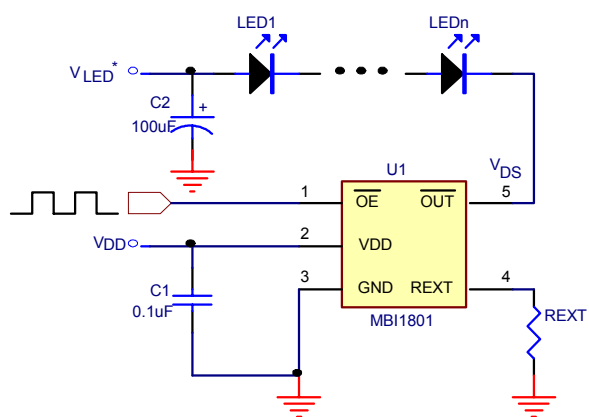

Figure 5

* $V_{LED} = V_{DS} + V_{F,LED} \times n$; $V_{F,LED}$: Forward voltage of LED; n: LED count

Constant Current

In LED lighting applications, MBI1801 provides nearly no variation in current from IC to IC. This can be achieved by:

- 1) The maximum current variation between ICs is less than ±6%.
- 2) In addition, the current characteristic of output stage is flat and users can refer to the figure as shown below. The output current can be kept constant regardless of the variations of LED forward voltages (V_F). This guarantees LED to be performed on the same brightness as user's specification.

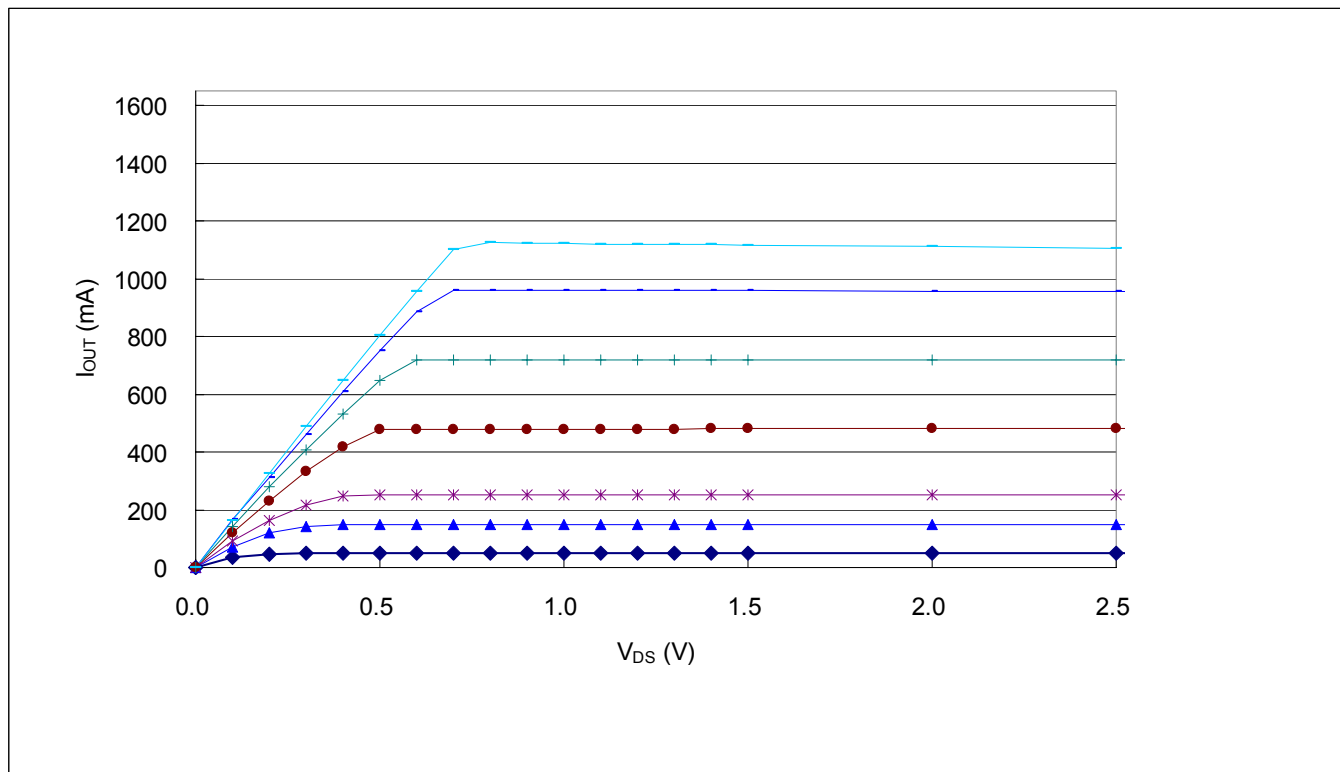

Figure 6

Setting Output Current

The output current of each channel (I_{OUT}) is set by an external resistor, R_{ext} . The relationship between I_{OUT} and R_{ext} is shown in the following figure.

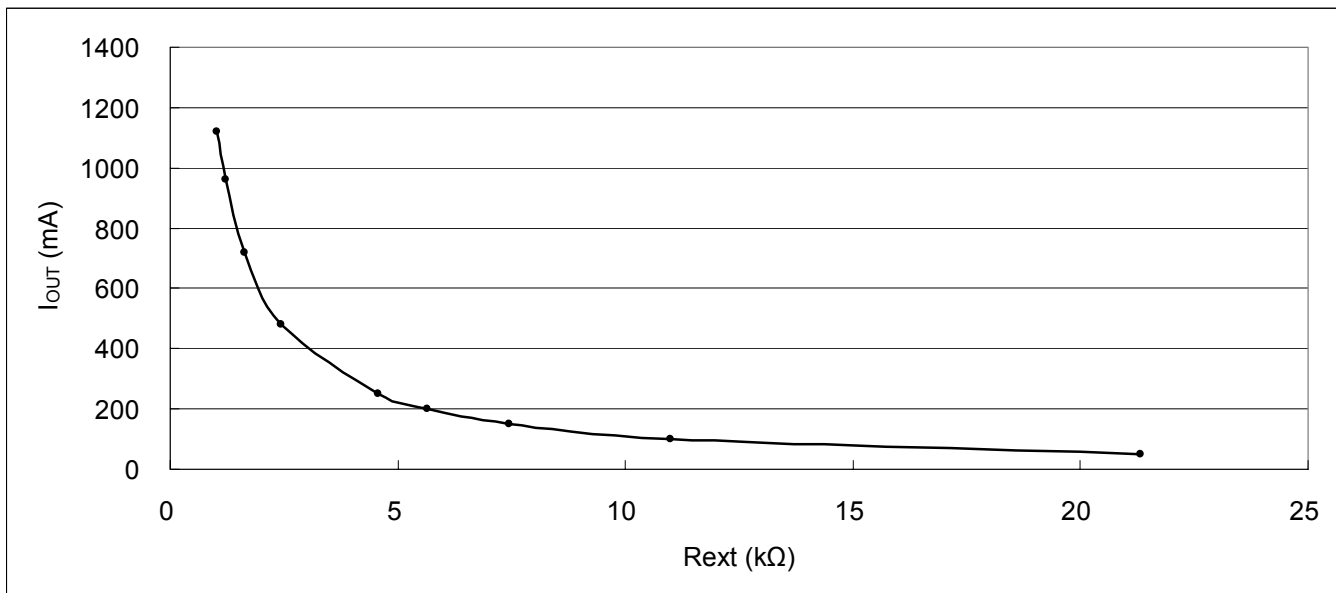

Figure 7

Also, the output current can be calculated from the equation:

$$V_{R-EXT} = 1.24V ;$$

$$R_{ext} = (V_{R-EXT} / I_{OUT}) \times 945 = (1.24V / I_{OUT}) \times 945,$$

$$I_{OUT} = (V_{R-EXT} / R_{ext}) \times 945 = (1.24V / R_{ext}) \times 945 \text{ within } \pm 6\% \text{ chip skew}$$

where R_{ext} is the resistance of the external resistor connected to R-EXT terminal and V_{R-EXT} is the voltage of R-EXT terminal. The magnitude of current (as a function of R_{ext}) is around 976mA at 1200Ω and 488mA at 2400Ω.

Soldering Process of “Pb-free” Package Plating*

Macroblock has defined "Pb-Free" to mean semiconductor products that are compatible with the current RoHS requirements and selected 100% pure tin (Sn) to provide forward and backward compatibility with both the current industry-standard SnPb-based soldering processes and higher-temperature Pb-free processes. Pure tin is widely accepted by customers and suppliers of electronic devices in Europe, Asia and the US as the lead-free surface finish of choice to replace tin-lead. Also, it is backward compatible to standard 215°C to 240°C reflow processes which adopt tin/lead (SnPb) solder paste. However, in the whole Pb-free soldering processes and materials, 100% pure tin (Sn) will all require up to 260°C for proper soldering on boards, referring to J-STD-020C as shown below.

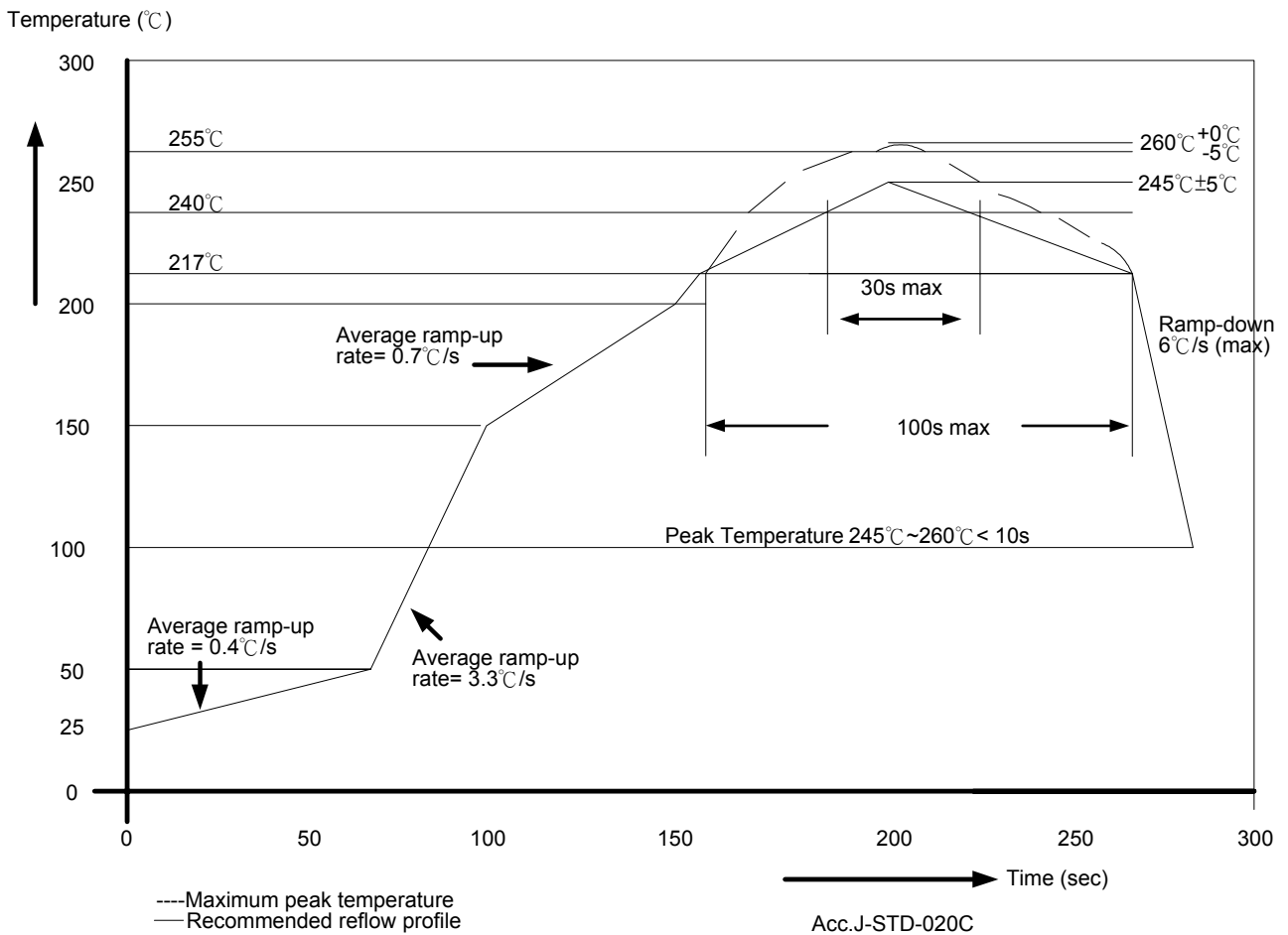

*Note1: For details, please refer to Macroblock’s “Policy on Pb-free & Green Package”.

Package Power Dissipation (P_D)

The maximum power dissipation, $P_D(\text{max}) = (T_{j,\text{max}} - T_a) / R_{\text{th}(j-a)}$, decreases as the ambient temperature increases.

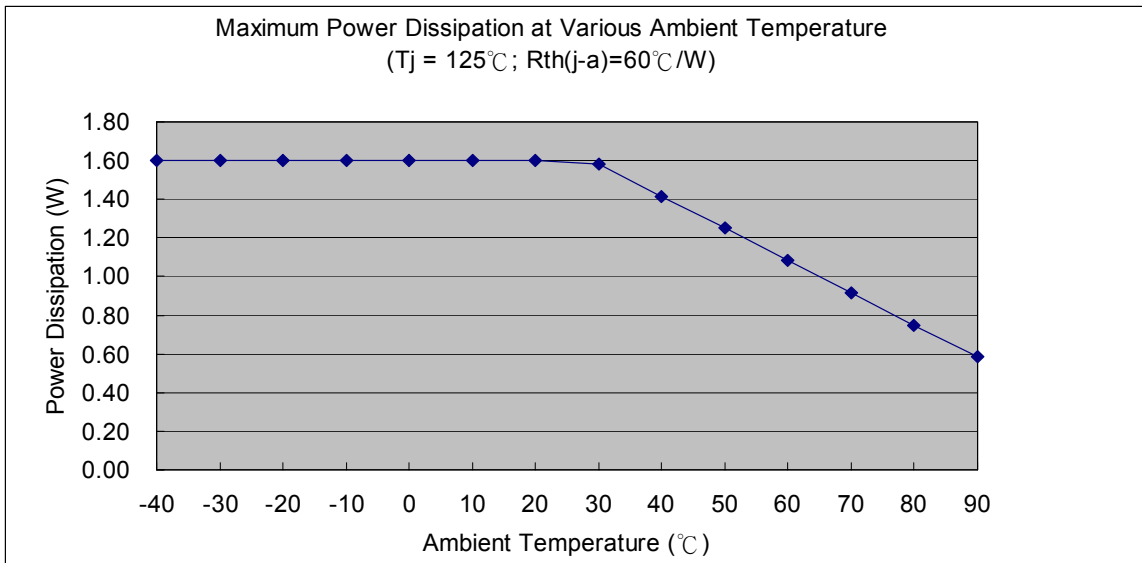

Figure 8

The maximum allowable package power dissipation is determined as $P_D(\text{max}) = (T_{j,\text{max}} - T_a) / R_{\text{th}(j-a)}$. When $\overline{\text{O\ddot{U}T}}$ is turned on, the actual package power dissipation is $P_D(\text{act}) = (I_{\text{DD}} \times V_{\text{DD}}) + (I_{\text{OUT}} \times \text{Duty} \times V_{\text{DS}})$. Therefore, to keep $P_D(\text{act}) \leq P_D(\text{max})$, the allowable maximum output current as a function of duty cycle is:

$$I_{\text{OUT}} = \{ [(T_j - T_a) / R_{\text{th}(j-a)}] - (I_{\text{DD}} \times V_{\text{DD}}) \} / V_{\text{DS}} / \text{Duty},$$

where $T_j = 125^\circ\text{C}$;

$$\text{Duty} = t_{\text{ON}} / T;$$

t_{ON} : the time of LEDs turning on; T : $\overline{\text{O\ddot{U}T}}$ signal period

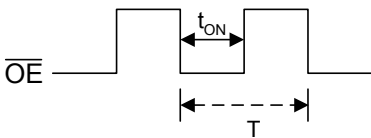

Load Supply Voltage (V_{LED})

MBI1801 is designed to operate with adequate V_{DS} to achieve constant current. V_{DS} together with I_{OUT} should not exceed the package power dissipation limit, $P_{D(max)}$.

As in Figure 4, $V_{DS} = V_{LED} - V_F$, and V_{LED} is the load supply voltage. $P_{D(act)}$ will be greater than $P_{D(max)}$, if V_{DS} drops too much voltage on the driver. In this case, it is recommended to use the lowest possible supply voltage or to set an external voltage reducer, V_{DROP} .

A voltage reducer lets $V_{DS} = (V_{LED} - V_F) - V_{DROP}$.

The resistor, R2, can be used in the applications as shown in Figure 4.

TP Function (Thermal Protection)

When the junction temperature exceeds the threshold, T_X (165°C), TP function turns off the output current. Thus, the junction temperature starts to decrease. As soon as the temperature is below 165°C, the output current will be turned on again. The on-state and off-state switch at a high frequency; thus, the blinking is imperceptible. However, the average output current is limited, and therefore, the driver is protected from being overheated.

Outline Drawing

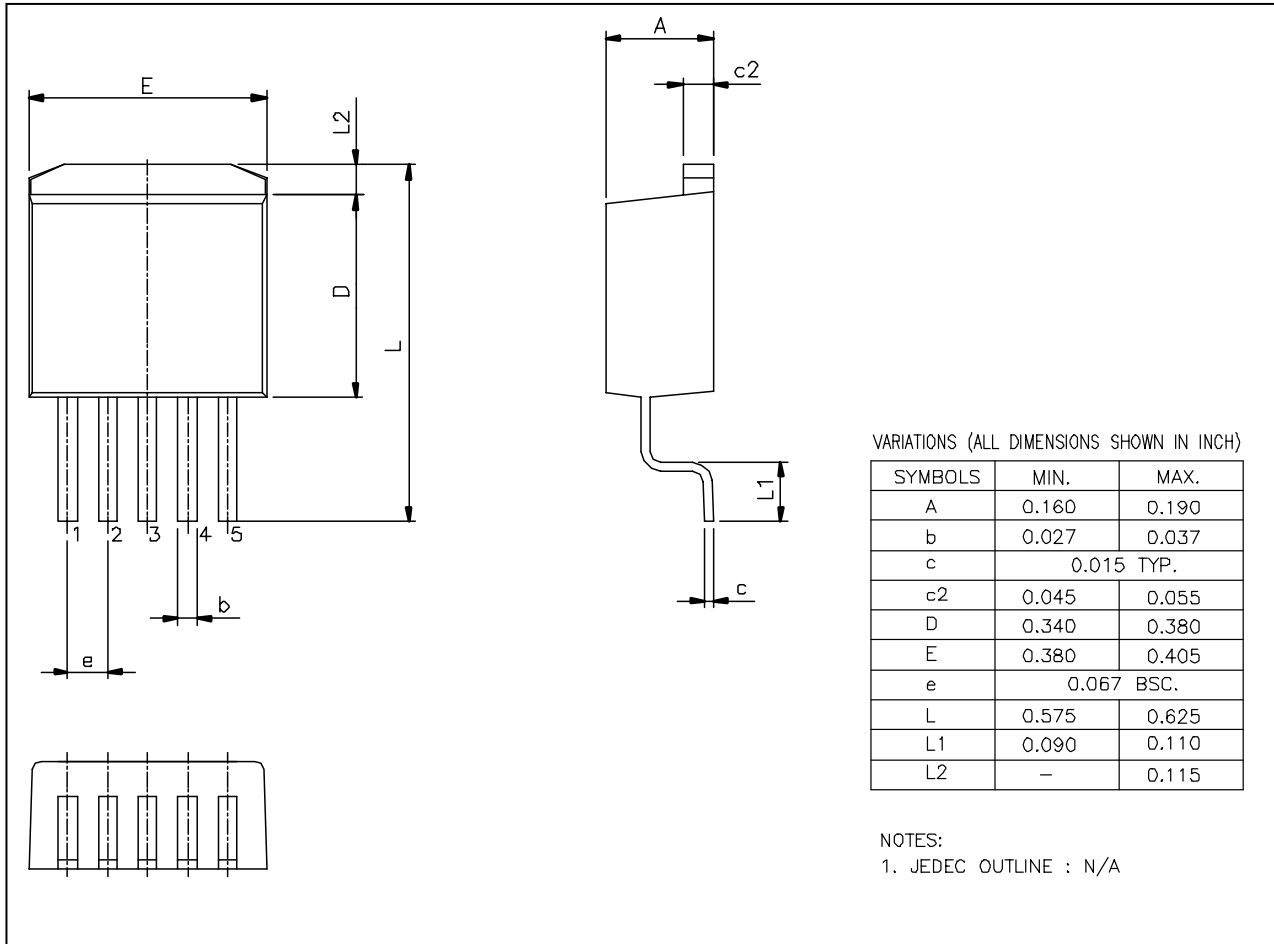

MBI1801GSD

Note: The unit for the outline drawing is inch.

Product Top-mark Information

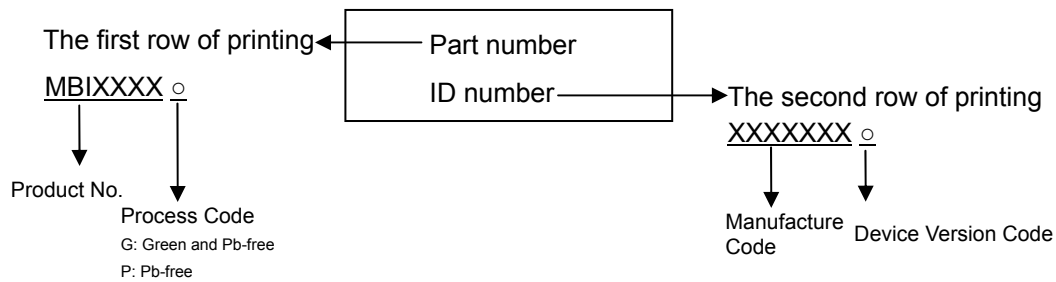

Product Revision History

Datasheet version	Device version code
V1.00	A
V1.01	A

Product Ordering Information

Part Number	Package Type	Weight (g)
MBI1801GSD	TO-265	1.468