

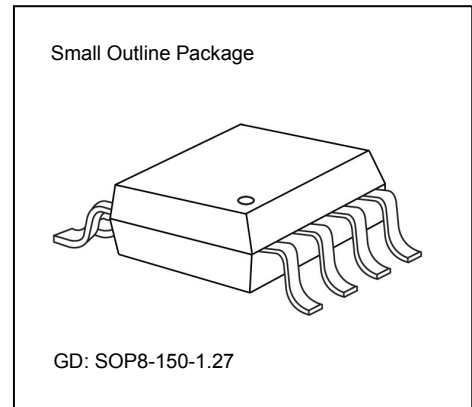

# All-Ways-On™ High-Power LED Driver

## Features

- 4 constant-current output channels
- Constant output current invariant to load voltage change
- Maximum output constant current per channel: 240mA
- Excellent output current accuracy:  
between channels: <math>\lt; \pm 3\% \text{ (max.)}</math>, and  
between ICs: <math>\lt; \pm 6\% \text{ (max.)}</math>
- Output current adjusted through an external resistor
- Schmitt trigger input
- 5V supply voltage
- Package type: "Pb-free & Green" SOP8 with thermal pad



Current Accuracy		Conditions
Between Channels	Between ICs	
<math>\lt; \pm 3\%</math>	<math>\lt; \pm 6\%</math>	$I_{OUT} = 40 \sim 240 \text{ mA}$

## Product Description

MBI1804 is an instant On/Off LED driver for high power LED applications and exploits PrecisionDrive™ and All-Ways-On™ technology to enhance its output characteristics. At MBI1804 output stage, four regulated current ports are designed to provide uniform and constant current sinks for driving LEDs within a large range of  $V_F$  variations.

With All-Ways-On™, MBI1804 provides users 4-channel constant current ports. Users may adjust the output current from 40 mA up to 240mA through an external resistor,  $R_{ext}$ , which gives users flexibility in controlling the light intensity of LEDs. In addition, users can precisely adjust LED brightness from 0% to 100% via output enable ( $\overline{OE}$ ) with Pulse Width Modulation.

Additionally, to ensure the system reliability, MBI1804 is built with TP (Thermal Protection) function and thermal pad. The TP function protects IC from over temperature (150°C). Also, the thermal pad enhances the power dissipation. As a result, a large amount of current can be handled safely in one package.

### Applications

- High-flux LED lighting
- Automotive interior lighting
- LCD backlight
- Photocopier
- Scanner

### Typical Application Circuit

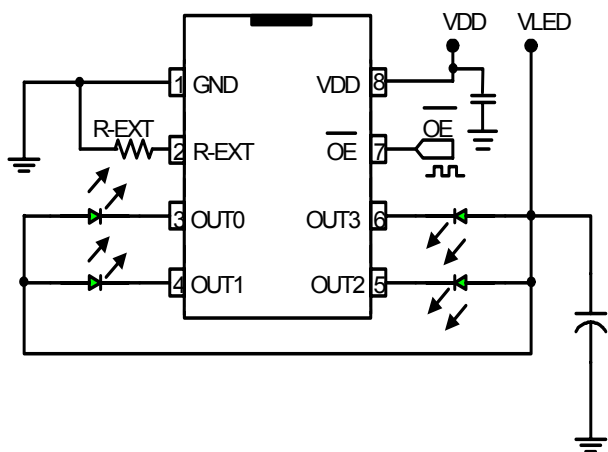
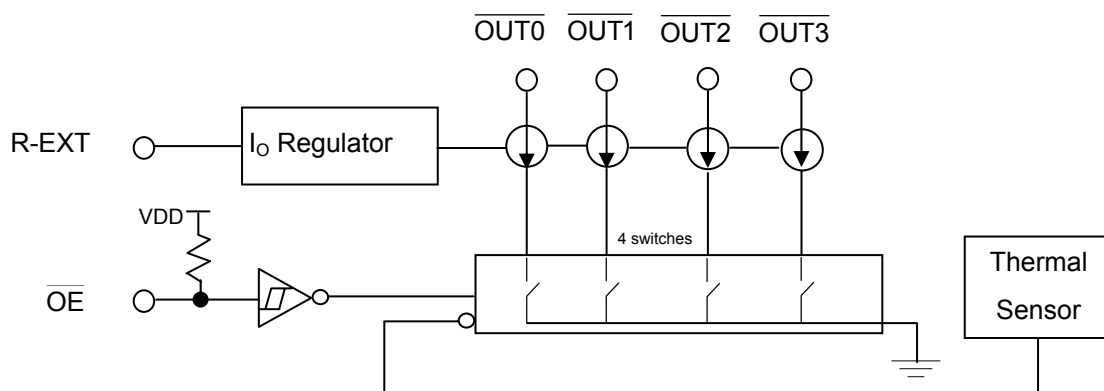
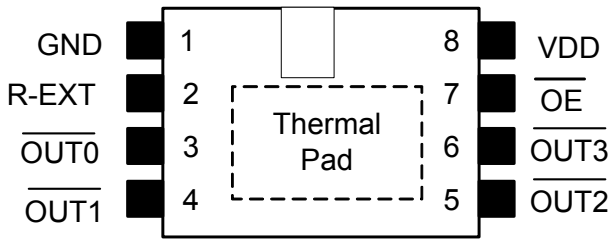

Figure 1

### Functional Diagram



**Pin Configuration**



MBI1804GD

**Pin Description**

Pin No.	Pin Name	Function
1	GND	Ground terminal for control logic and current sink
3, 4, 5, 6	OUT0 ~ OUT3	Constant current output terminals
7	OE	Output enable terminal When OE is active (low), the output pins are enabled; when OE is inactive (high), all output pins are turned OFF (blanked).
2	R-EXT	Terminal used to connect an external resistor (R <sub>ext</sub> ) for setting up output current for all output channels
8	VDD	5V supply voltage terminal
-	Thermal Pad	Power dissipation terminals connected to GND*

\*To eliminate the noise influence, the thermal pad is suggested to be connected to GND on PCB.

In addition, desired thermal conductivity will be improved, if a heat-conducting copper foil on PCB is soldered with thermal pad.

**Maximum Ratings**

Characteristic		Symbol	Rating	Unit
Supply Voltage		$V_{DD}$	0~7.0	V
Input Voltage		$V_{IN}$	-0.4~ $V_{DD} + 0.4$	V
Output Current		$I_{OUT}$	360*	mA
Sustaining Voltage		$V_{DS}$	-0.5~+17.0	V
GND Terminal Current		$I_{GND}$	1000	mA
Power Dissipation* (On PCB, $T_a=25^{\circ}C$ )	SOP8	$P_D$	0.8	W
Thermal Resistance (By simulation)		$R_{th(j-a)}$	33.39	$^{\circ}C/W$
Empirical Thermal Resistance* (On PCB, $T_a=25^{\circ}C$ )			125	
Operating Junction Temperature		$T_{j,max}$	125	$^{\circ}C$
Operating Temperature		$T_{opr}$	-40~+85	$^{\circ}C$
Storage Temperature		$T_{stg}$	-55~+150	$^{\circ}C$

\*Users must notice that the power dissipation (almost equaling to  $I_{OUT} \times V_{DS}$ ) should be within the Safe Operation Area shown in Figure 6.

**Electrical Characteristics**

Characteristic		Symbol	Condition	Min.	Typ.	Max.	Unit
Supply Voltage		$V_{DD}$	-	4.5	5.0	5.5	V
Sustaining Voltage at $\overline{OUT}$ pin		$V_{DS}$	$\overline{OUT0} \sim \overline{OUT3}$	-	-	17.0	V
Output Current		$I_{OUT}$	DC Test Circuit	20	-	240*	mA
Input Voltage	"H" level	$V_{IH}$	$T_a = -40 \sim 85^\circ C$	$0.7 \times V_{DD}$	-	$V_{DD}$	V
	"L" level	$V_{IL}$	$T_a = -40 \sim 85^\circ C$	GND	-	$0.3 \times V_{DD}$	V
Output Leakage Current		$I_{OH}$	$V_{OH} = 17.0V$	-	-	0.5	$\mu A$
Output Current 1		$I_{OUT1}$	$V_{DS} = 0.6V$ $R_{ext} = 2.4k\Omega$	-	122	-	mA
Current Skew 1		$dI_{OUT1}$	$I_{OL} = 122mA$ $V_{DS} = 0.6V$ $R_{ext} = 2.4k\Omega$	-	$\pm 1$	$\pm 3$	%
Output Current 2		$I_{OUT2}$	$V_{DS} = 0.8V$ $R_{ext} = 1.3k\Omega$	-	225	-	mA
Current Skew 2		$dI_{OUT2}$	$I_{OL} = 225mA$ $V_{DS} = 0.8V$ $R_{ext} = 1.3k\Omega$	-	$\pm 1$	$\pm 3$	%
Regulation of Output Current vs. Sustaining Voltage		$\%/dV_{DS}$	$V_{DS}$ within 1.0V and 3.0V	-	$\pm 0.1$	-	% / V
Regulation of Output Current vs. Supply Voltage		$\%/dV_{DD}$	$V_{DD}$ within 4.5V and 5.5V	-	$\pm 1$	-	% / V
Pull-up Resistor		$R_{IN(up)}$	$\overline{OE}$	250	500	800	K $\Omega$
Junction Temperature Threshold		$T_x$	When $T_j$ approaches $T_x$ and $\overline{OUT}$ is shut off.	-	150	-	$^\circ C$
Supply Current	"OFF"	$I_{DD(off) 1}$	$R_{ext} = \text{Open}, \overline{OUT0} \sim \overline{OUT3} = \text{Off}$	-	5	9	mA
		$I_{DD(off) 2}$	$R_{ext} = 2.4k\Omega, \overline{OUT0} \sim \overline{OUT3} = \text{Off}$	-	6	10	
		$I_{DD(off) 3}$	$R_{ext} = 1.3k\Omega, \overline{OUT0} \sim \overline{OUT3} = \text{Off}$	-	8	12	
	"ON"	$I_{DD(on) 1}$	$R_{ext} = 2.4k\Omega, \overline{OUT0} \sim \overline{OUT3} = \text{On}$	-	6	10	
		$I_{DD(on) 2}$	$R_{ext} = 1.3k\Omega, \overline{OUT0} \sim \overline{OUT3} = \text{On}$	-	7	10	

\* Each output current,  $I_{OUT}$ , can be driven up to 360mA, but the total output current should be smaller than 1A.

**Test Circuit for Electrical Characteristics**

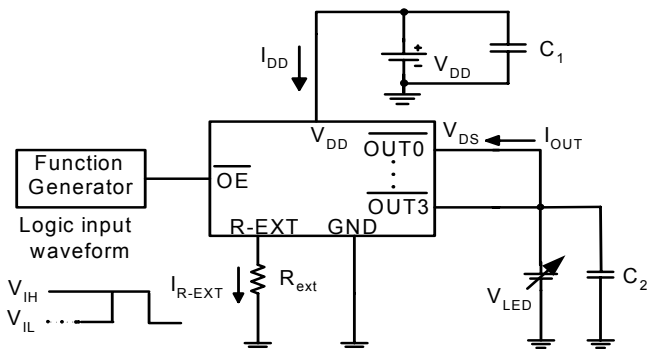

Figure 2

**Switching Characteristics**

Characteristic	Symbol	Condition	Min.	Typ.	Max.	Unit	
Propagation Delay Time ("L" to "H")	$\overline{OE} - \overline{OUTn}$	$V_{DD} = 5.0\text{ V}$ $V_{DS} = 1.0\text{ V}$ $V_{IH} = V_{DD}$ $V_{IL} = \text{GND}$ $R_{ext} = 1226\Omega$ $(I_{OUTn} = 240\text{ mA})$ $V_L = 4.0\text{ V}$ $R_L = 11.896\Omega$ $C_L = 10\text{ pF}$	0.3	0.5	1	$\mu\text{s}$	
Propagation Delay Time ("H" to "L")	$\overline{OE} - \overline{OUTn}$		$t_{pHL}$	0.3	0.5	1	$\mu\text{s}$
Pulse Width	$\overline{OE}$		$t_{w(OE)}$	1	-	-	$\mu\text{s}$
Output Rise Time of $\overline{OUT}$ (turn off)	$t_{or}$		1	0.3	0.5	$\mu\text{s}$	
Output Fall Time of $\overline{OUT}$ (turn on)	$t_{of}$		1	0.3	0.5	$\mu\text{s}$	

**Test Circuit for Switching Characteristics**

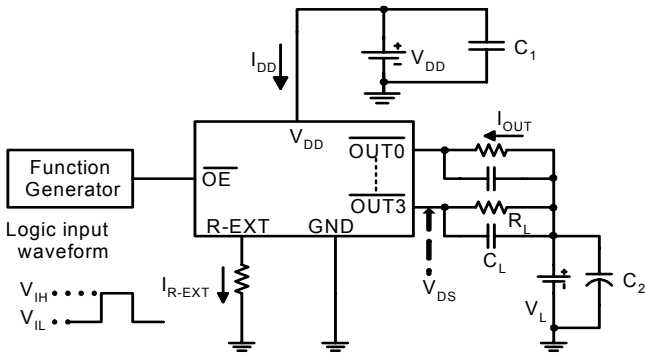
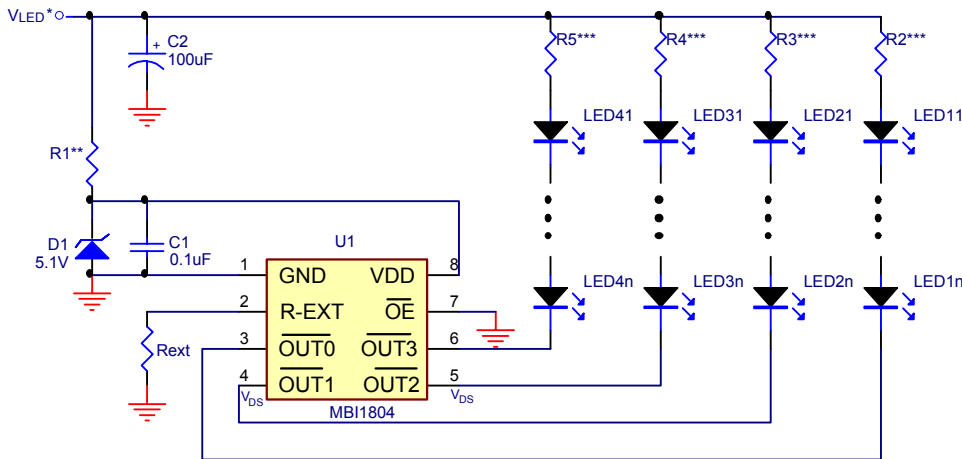

Figure 3

**Application Information**

**Application Circuits**

(a) MBI1804 application circuit, where  $V_{LED}$  and  $V_{DD}$  share a single voltage source.



\*  $V_{LED} > V_{DS} + V_{F,LED} \times n$ ;  $V_{F,LED}$ : Forward voltage of LED; n: LED count

\*\*  $R1 = (V_{LED} - 5.1V) / I_{DD}$ ; refer to Electrical Characteristics for  $I_{DD}$

\*\*\*  $R2 \sim R5 = [V_{LED} - V_{DS} - (V_{F,LED} \times n)] / I_{LED}$

(b) MBI1804 application circuit with dimming control by PWM signal, where  $V_{LED}$  and  $V_{DD}$  use voltage sources separately.

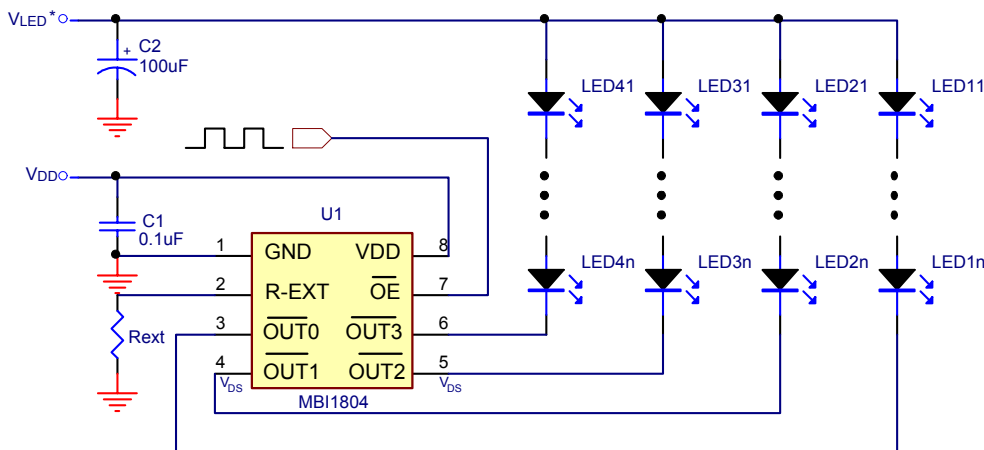

\*  $V_{LED} = V_{DS} + V_{F,LED} \times n$ ;  $V_{F,LED}$ : Forward voltage of LED; n: LED count

Figure 4

### Constant Current

In LED lighting applications, MBI1804 provides nearly no variation in current from channel to channel and from IC to IC. This can be achieved by:

- 1) The maximum current variation between channels is less than  $\pm 3\%$ , and that between ICs is less than  $\pm 6\%$ .
- 2) In addition, the current characteristic of output stage is flat and users can refer to the figure as shown below. The output current can be kept constant regardless of the variations of LED forward voltages ( $V_F$ ). This guarantees LED to be performed on the same brightness as user's specification.

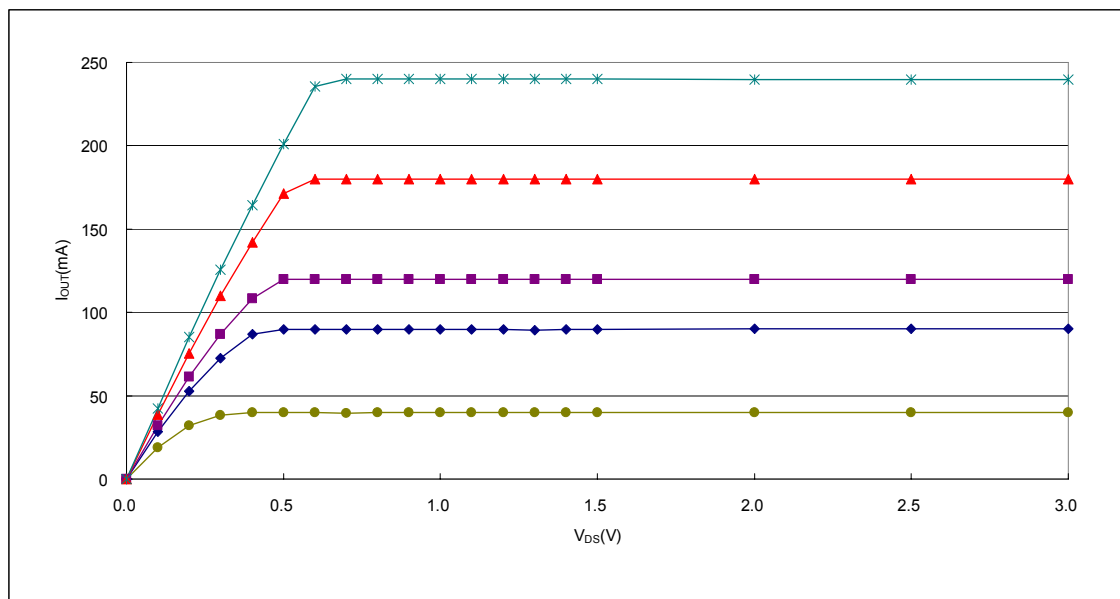

Figure 5

### Setting Output Current

The output current of each channel ( $I_{OUT}$ ) is set by an external resistor,  $R_{ext}$ . The relationship between  $I_{OUT}$  and  $R_{ext}$  is shown in the following figure.

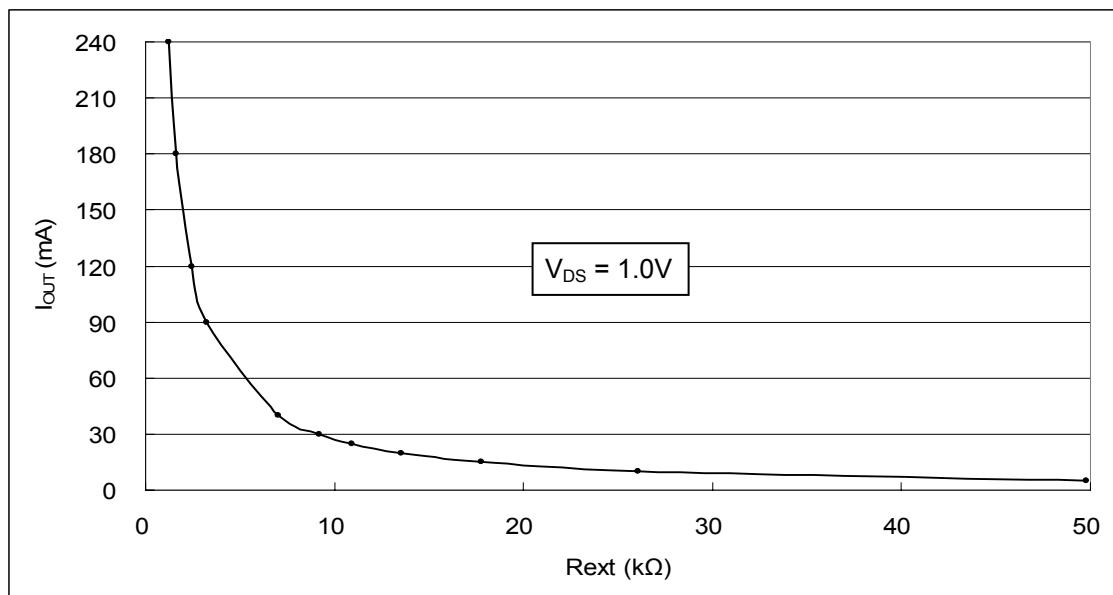

Figure 6

Also, the output current can be calculated from the equation:

$$V_{R-EXT} = 1.24V ;$$

$$R_{ext} = (V_{R-EXT} / I_{OUT}) \times 236 = (1.24V / I_{OUT}) \times 236$$

$$I_{OUT} = (V_{R-EXT} / R_{ext}) \times 236 = (1.24V / R_{ext}) \times 236 \text{ within } \pm 6\% \text{ chip skew}$$

where  $R_{ext}$  is the resistance of the external resistor connected to R-EXT terminal;  $V_{R-EXT}$  is the voltage of R-EXT terminal. The magnitude of current (as a function of  $R_{ext}$ ) is around 225mA at 1.3kΩ and 122mA at 2.4kΩ.

**Soldering Process of “Pb-free & Green” Package Plating\***

Macroblock has defined "Pb-Free & Green" to mean semiconductor products that are compatible with the current RoHS requirements and selected **100% pure tin (Sn)** to provide forward and backward compatibility with both the current industry-standard SnPb-based soldering processes and higher-temperature Pb-free processes. Pure tin is widely accepted by customers and suppliers of electronic devices in Europe, Asia and the US as the lead-free surface finish of choice to replace tin-lead. Also, it is backward compatible to standard 215°C to 240°C reflow processes which adopt tin/lead (SnPb) solder paste. However, in the whole Pb-free soldering processes and materials, 100% pure tin (Sn) will all require up to 260°C for proper soldering on boards, referring to J-STD-020C as shown below.

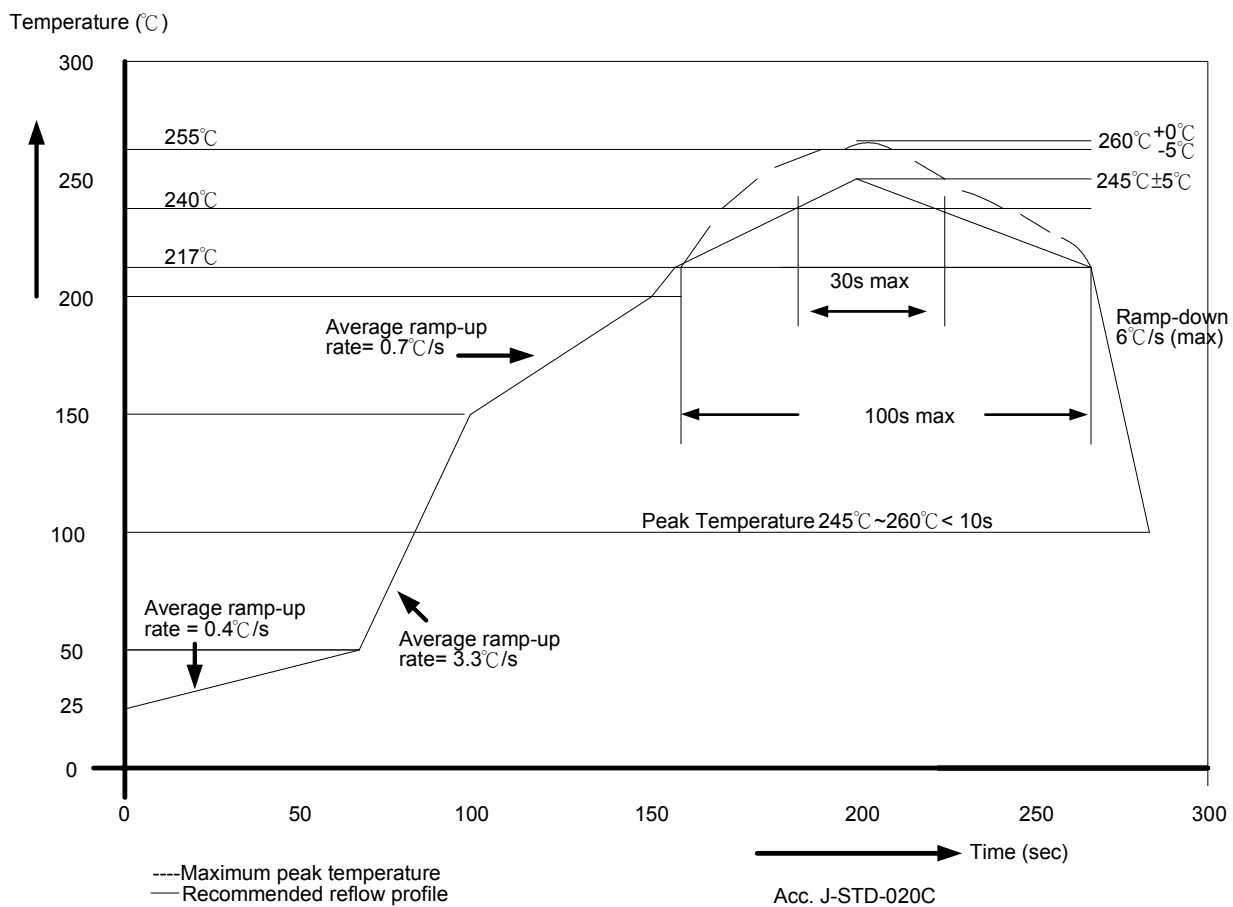

\*Note: For details, please refer to Macroblock’s “Policy on Pb-free & Green Package”.

### Package Power Dissipation (P<sub>D</sub>)

The maximum power dissipation,  $P_D(\text{max}) = (T_{j,\text{max}} - T_a) / R_{th(j-a)}$ , decreases as the ambient temperature increases.

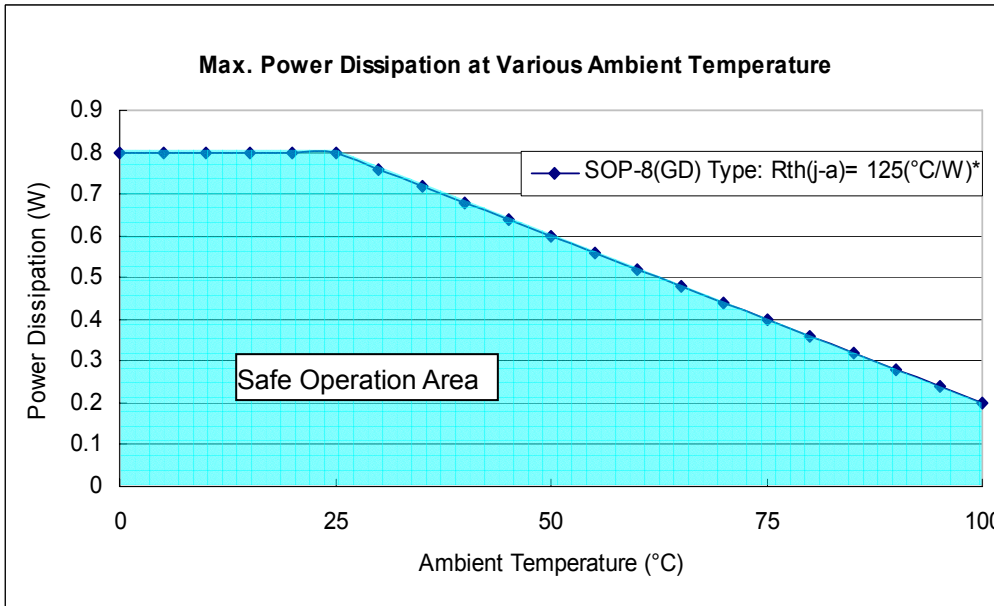

Figure 7

The maximum allowable package power dissipation is determined as  $P_D(\text{max}) = (T_{j,\text{max}} - T_a) / R_{th(j-a)}$ . When 4 output channels are turned on simultaneously, the actual package power dissipation is  $P_D(\text{act}) = (I_{DD} \times V_{DD}) + (I_{OUT} \times \text{Duty} \times V_{DS} \times 4)$ . Therefore, to keep  $P_D(\text{act}) \leq P_D(\text{max})$ , the allowable maximum output current as a function of duty cycle is:

$$I_{OUT} = \{ [(T_j - T_a) / R_{th(j-a)}] - (I_{DD} \times V_{DD}) \} / V_{DS} / \text{Duty} / 4,$$

where  $T_j = 125^\circ\text{C}$ ;

Duty =  $t_{ON} / T$ ;

$t_{ON}$ : the time of LEDs turning on;  $T$ :  $\overline{\text{OE}}$  signal period

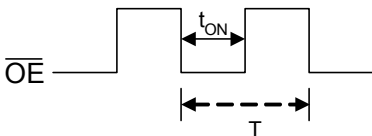

\*Note: The empirical thermal resistor  $R_{th(j-a)} = 125^\circ\text{C/W}$  is based on the following structure.

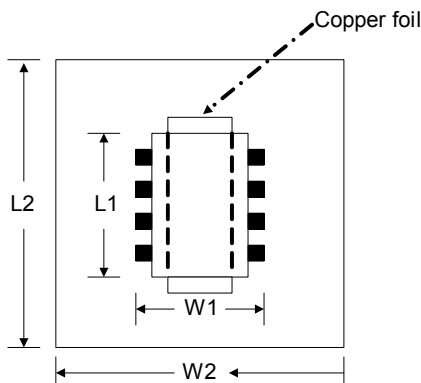

The PCB area  $L2 \times W2$  is 4 times of the IC's area  $L1 \times W1$ .  
 The thickness of the PCB is 1.6mm, copper foil 1 Oz. The thermal pad on the IC's bottom has to be mounted on the copper foil.

### TP Function (Thermal Protection)

When the junction temperature exceeds the threshold,  $T_x$  (15065°C), TP function turns off the output current. As soon as the temperature is below 15065°C, the output current will be turned on again. The on-state and off-state switch at a high frequency; thus, the blinking is imperceptible. However, the average output current is limited, and therefore, the driver is protected from being overheated.

### Load Supply Voltage ( $V_{LED}$ )

MBI1804 is designed to operate with adequate  $V_{DS}$  to achieve constant current.  $V_{DS}$  together with  $I_{OUT}$  should not exceed the package power dissipation limit,  $P_{D(max)}$ .

As in Figure 8,  $V_{DS} = V_{LED} - V_F$ , and  $V_{LED}$  is the load supply voltage.  $P_{D(act)}$  will be greater than  $P_{D(max)}$ , if  $V_{DS}$  drops too much voltage on the driver. In this case, it is recommended to use the lowest possible supply voltage or to set an external voltage reducer,  $V_{DROP}$ .

A voltage reducer lets  $V_{DS} = (V_{LED} - V_F) - V_{DROP}$ .

Resistors can be used in the applications as shown in Figure 8.

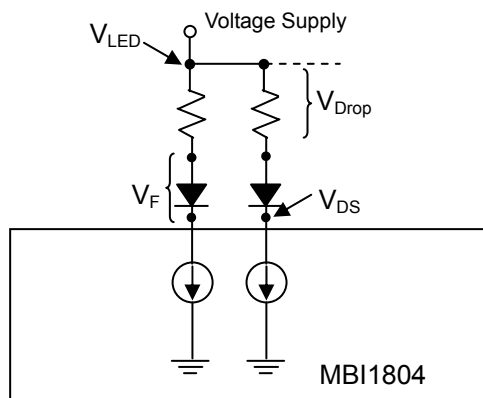
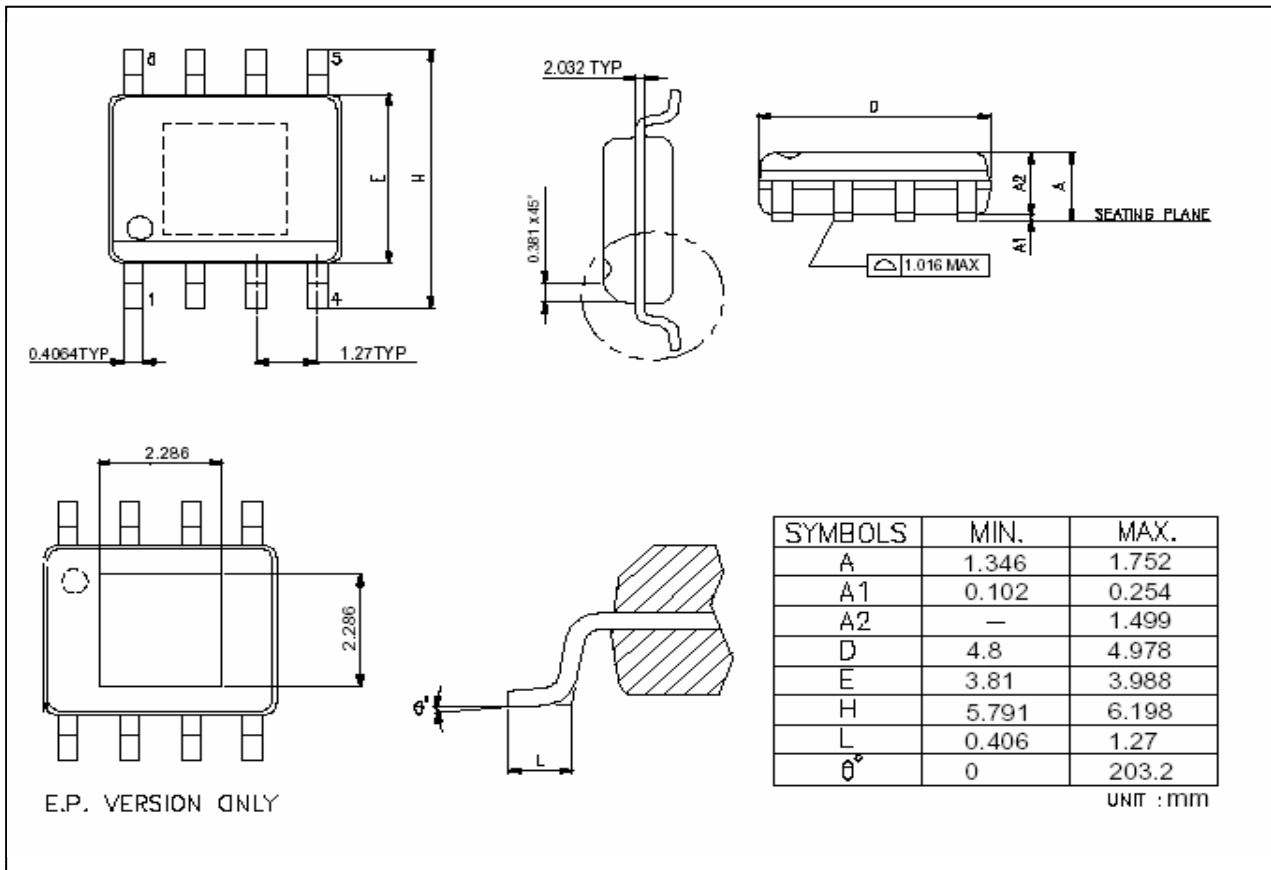

Figure 7

**Outline Drawing**



SOP-8-150-1.27

Note: The unit for the outline drawing is mm.

**Product Top-mark Information**

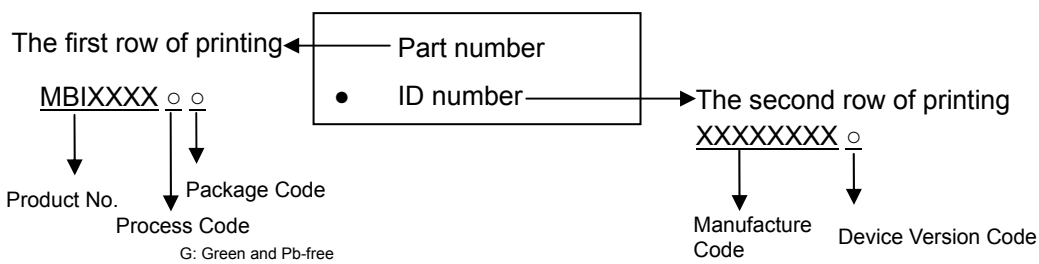

**Product Revision History**

Datasheet Version	Device Version Code
V1.00	Not defined
V1.01	A
V1.02	B

**Product Revision History**

Part Number	Package Type	Weight (g)
MBI1804GD	SOP8-150-1.27	0.07